

Left side View

See cylinder drawing for dimensions

Drill and tap 6-32
3 places

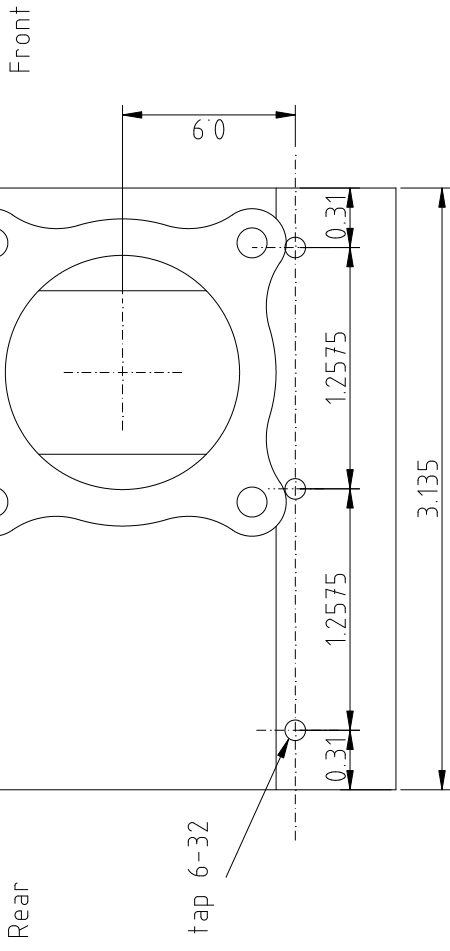

Top View

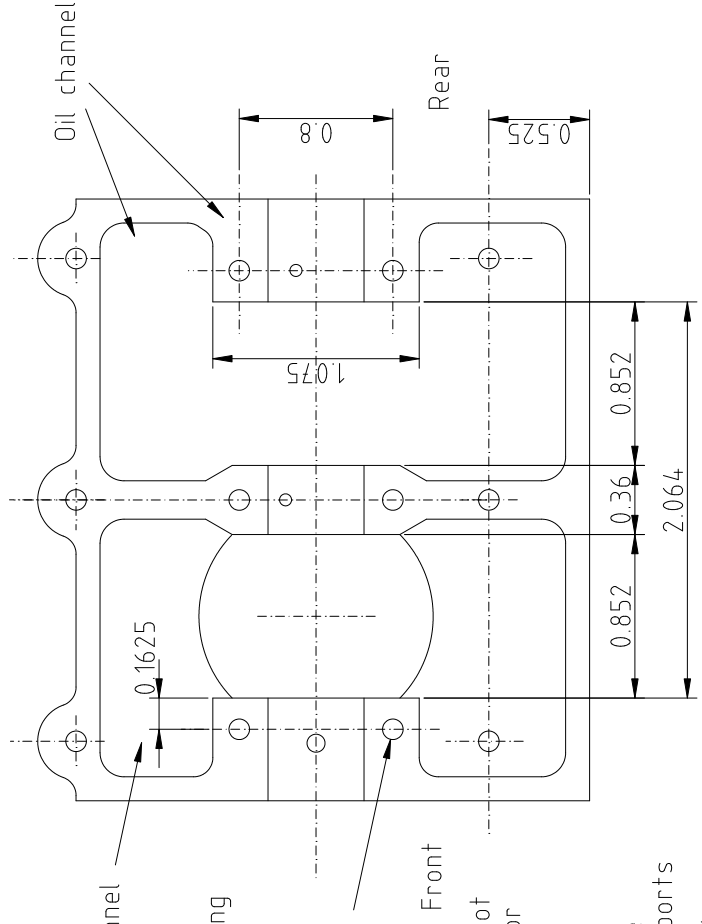
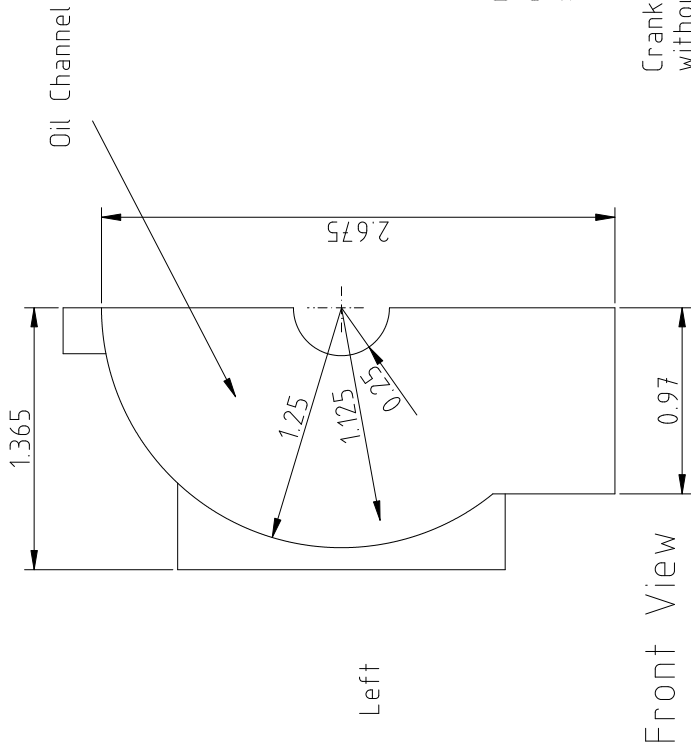
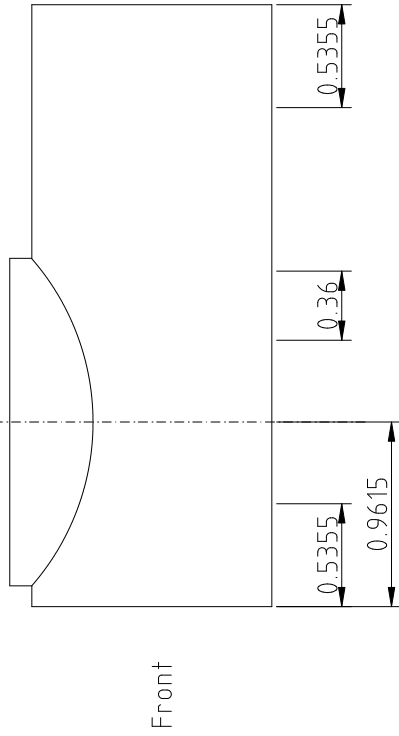

Oil channel is a 3/32 dia
brass tubing in the casting

Casting thickness should not
exceed 1/8 thick except for
structural purposes.

Crankcase - Make a second one
without crankshaft bearing supports
for the opposite side of engine.